

東京都型角形CD柵



仕様寸法表 (単位 mm)

名称	CD柵	A	B	H	T	a鉄筋	b鉄筋	重量 kg
側塊	600	600	720	300	60	6×3本	6×16本	109
	500	500	620	300	60	4×3	4×12	94
	450	450	570	300	60	4×3	4×12	84
	360	360	460	300	50	4×3	4×8	57
	300	300	400	300	50	3. 2×3	3. 2×8	47
半側塊	600	600	720	150	60	6×2	6×12	54
	500	500	620	150	60	4×2	4×12	47
	450	450	570	150	60	4×2	4×12	42
	360	360	460	150	50	4×2	4×8	28
	300	300	400	150	50	3. 2×2	3. 2×8	24

協同コンクリート

東京都型角形CD柵

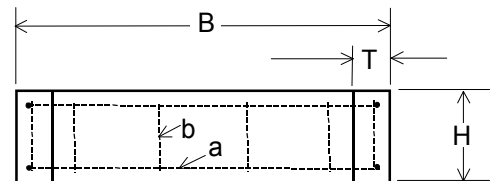
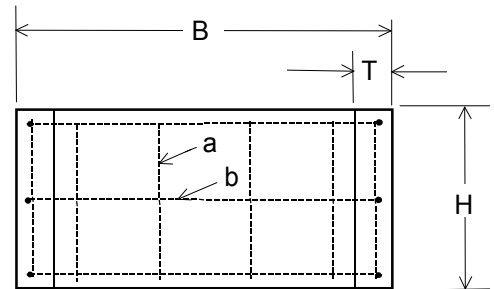
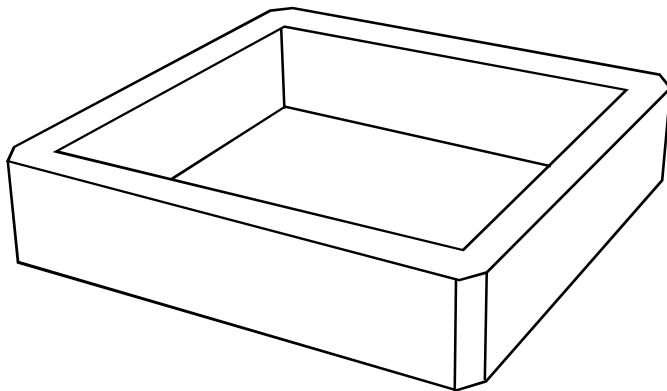
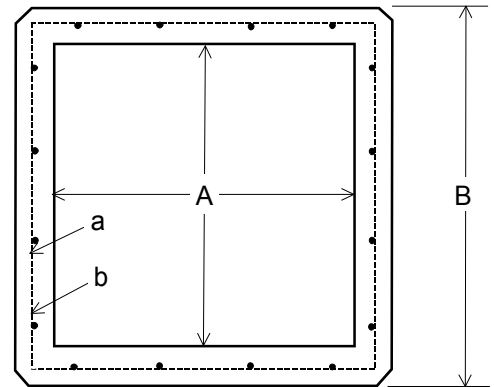
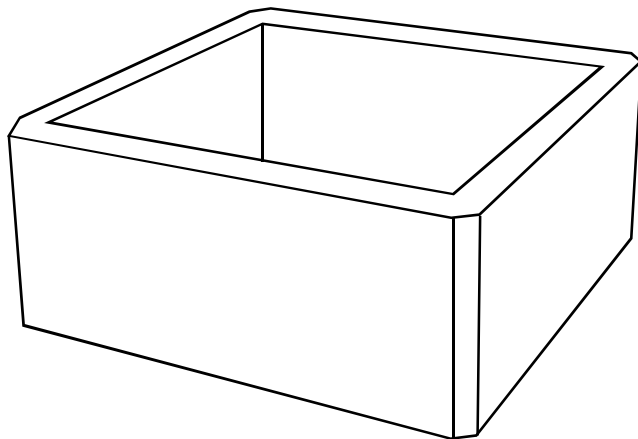

仕様寸法表 (単位 mm)

名称	CD柵	A	B	H	T	a 鉄筋	b 鉄筋	重量 kg
側塊	600	600	720	300	60	6×3本	6×16本	109
	500	500	620	300	60	4×3	4×12	94
	450	450	570	300	60	4×3	4×12	84
	360	360	460	300	50	4×3	4×8	57
	300	300	400	300	50	3. 2×3	3. 2×8	47
半側塊	600	600	720	150	60	6×2	6×12	54
	500	500	620	150	60	4×2	4×12	47
	450	450	570	150	60	4×2	4×12	42
	360	360	460	150	50	4×2	4×8	28
	300	300	400	150	50	3. 2×2	3. 2×8	24