

鉄筋コンクリートU形



仕様寸法表 (単位 mm)

名称	A	B	C	D	E	F	L	鉄筋	重量
300B	300	400	300	50	60	360	600	4, 3.2mm×14本	79kg
240	240	330	240	45	50	290	600	3.2×12	55
180	180	250	180	35	40	220	600	3.2×10	33
150	150	210	150	30	35	185	600	2.6×10	22
120	120	180	120	25	30	155	600	2.6×10	19
90	90	140	90	20	25	120	600	2.6×7	12

鉄筋コンクリートU形

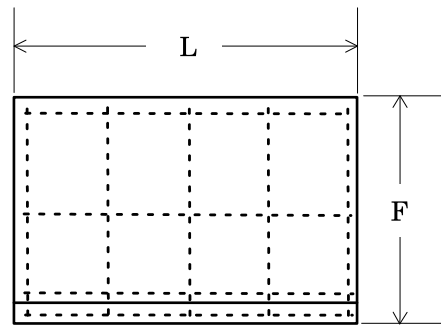
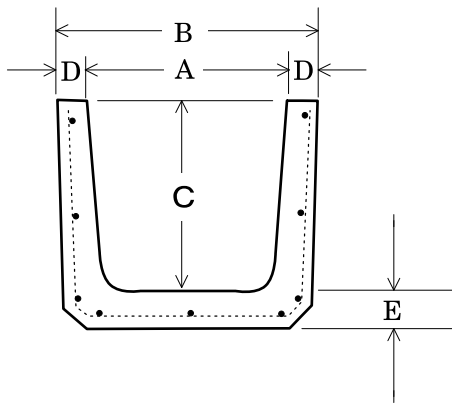
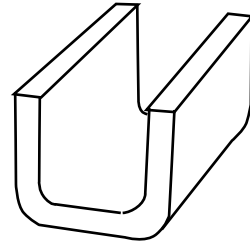
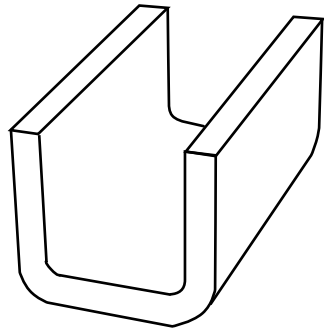

仕様寸法表 (単位 mm)

名称	A	B	C	D	E	F	L	鉄筋	重量
300B	300	400	300	50	60	360	600	4, 3.2mm×14本	79kg
240	240	330	240	45	50	290	600	3.2×12	55
180	180	250	180	35	40	220	600	3.2×10	33
150	150	210	150	30	35	185	600	2.6×10	22
120	120	180	120	25	30	155	600	2.6×10	19
90	90	140	90	20	25	120	600	2.6×7	12